



**SLO Sail and Canvas**

**645 Tank Farm Rd Suite G**

**San Luis Obispo, CA 93401**

**slosailandcanvas@yahoo.com**

### **MacGregor Venture 15 (Banana Hull) Mast and Boom Measurements**

SLO Sail and Canvas is a small band of sailing enthusiasts. As a group we are dedicated to providing high-quality, hand-made products, built in our San Luis Obispo, California loft, with materials manufactured in the USA. We realize that great, American-made products must also be competitively priced. We don't think you can beat our quality or our price no matter where you shop (or cyber-shop).

Whether you sail for pleasure or competition, we specialize in building new custom sails for your particular boat. Our expert sailmaker has years of sailing experience to craft a custom sail just for you. For precision, your sail is first computer designed via a specialized sailmaking program, cut on our large textile CNC plotter cutter, then hand assembled and sewn by our expert staff. We are more than happy to build you a new sail, jib, or spinnaker custom fit to your particular boat and sailing type. Give us a call for more information.

Our mission is to supply you with the highest quality and best fit boat covers, trampolines, sails, and line kits plus expert advice and information so you can keep your boat on the water for as long as possible. If you need additional info our website has links to the Venture 15 Banana Hull (and Straight Hull) Assembly Manual.



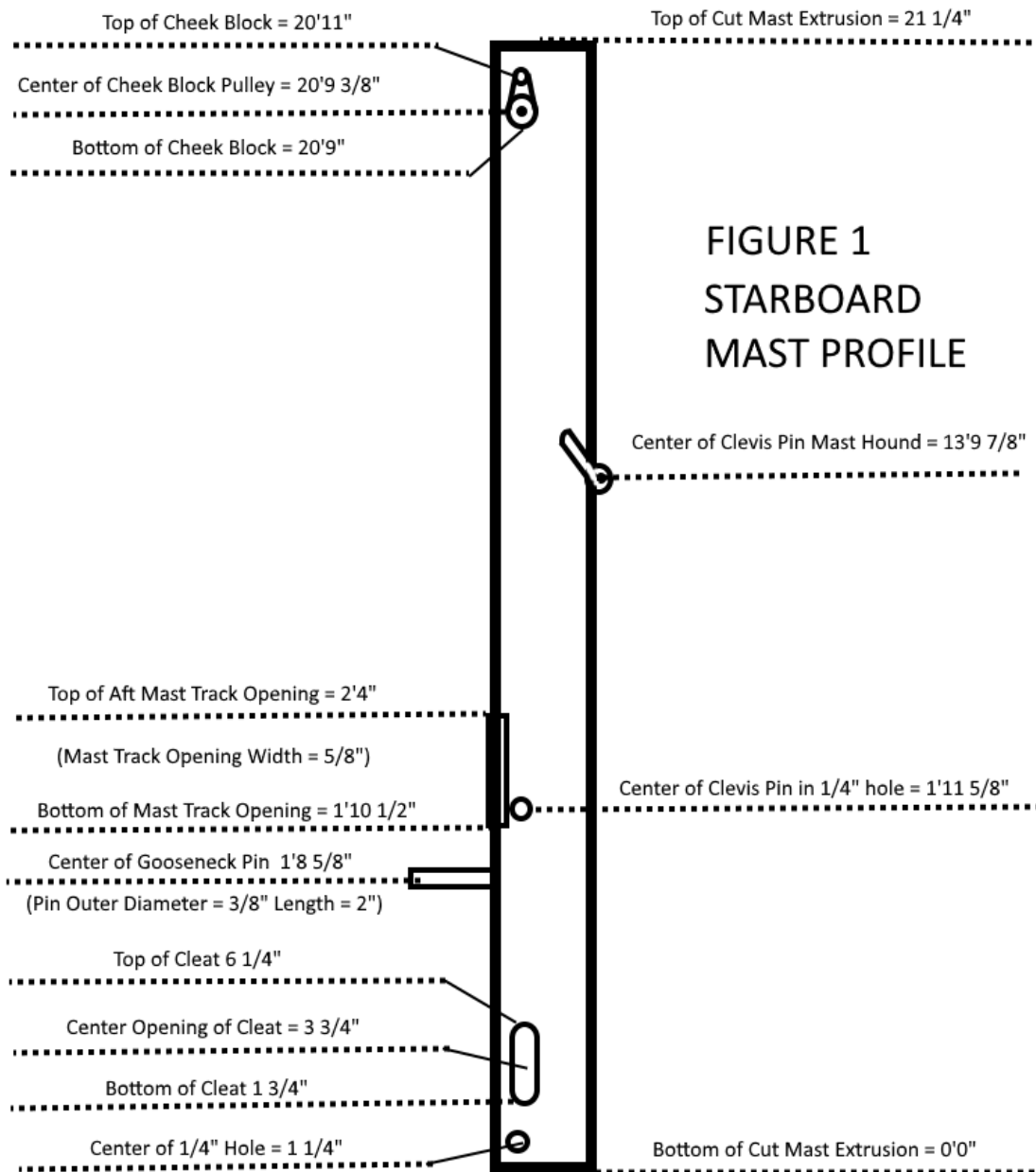

FIGURE 1  
STARBOARD  
MAST PROFILE

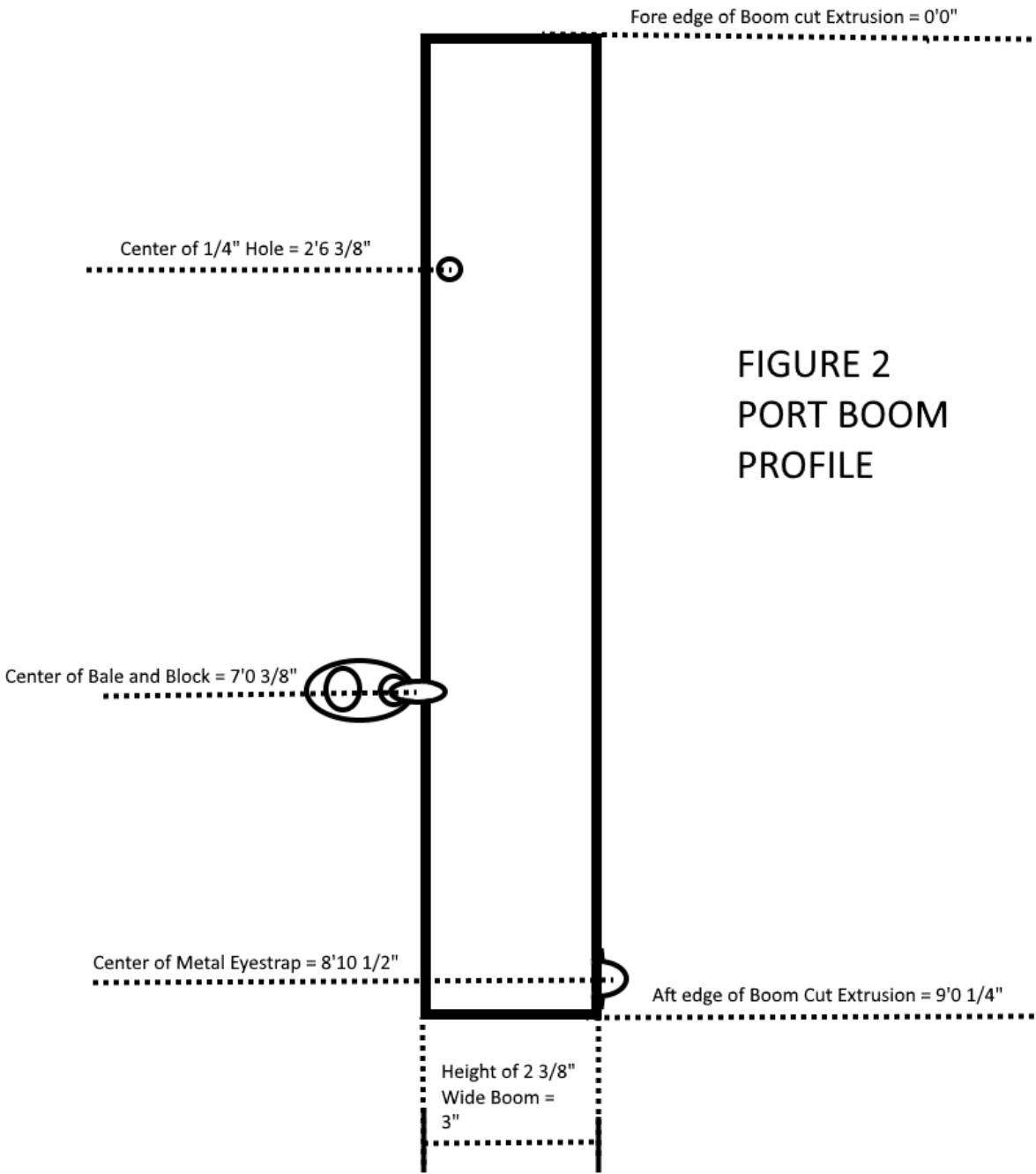

FIGURE 2  
PORT BOOM  
PROFILE

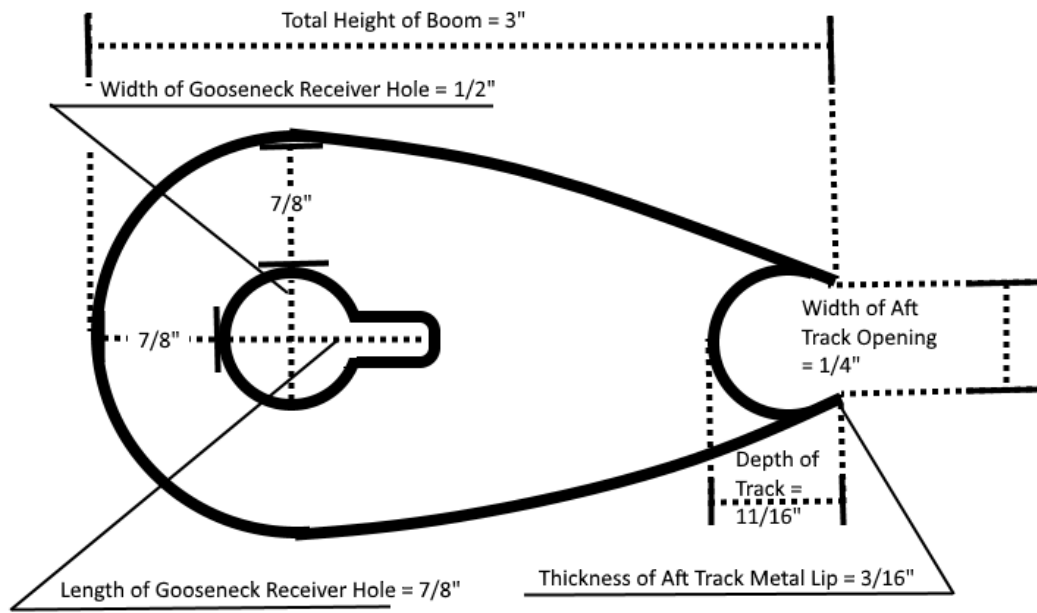
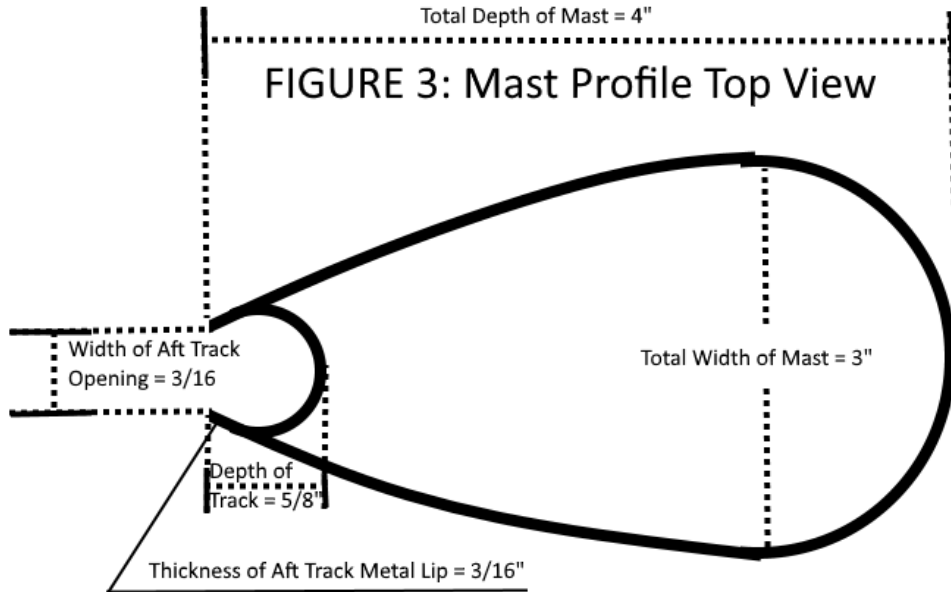

FIGURE 4: Boom Profile Fore Edge View